

RPC units for BML chambers - Sector 1

Version 11.5.05

Sul lato RO gli MDT hanno due supporti meccanici mentre sul lato HV ne hanno uno solo

- Splitter
- PAD
- Wired_or
- hole

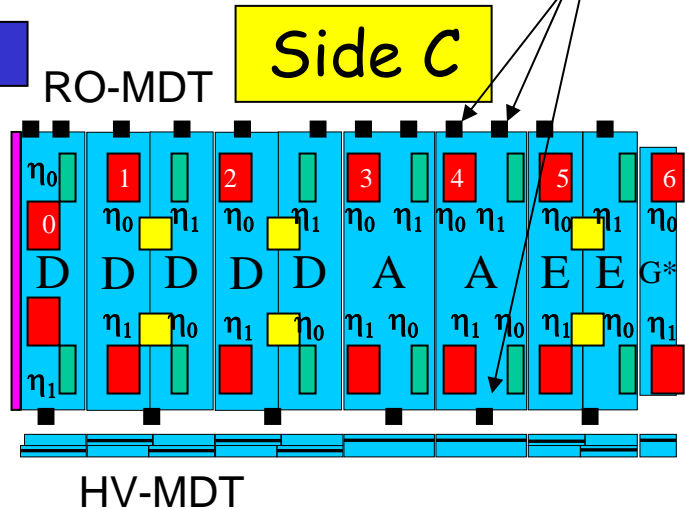
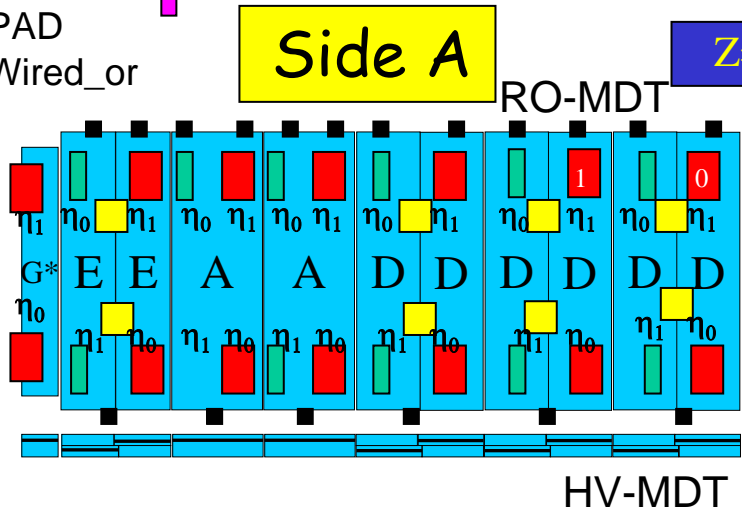

Lo schema è valido guardando l'RPC dove sono montate le scatole del trigger. Fate attenzione ai lati HV e RO delle camere MDT

Chambers are seen from outside; that is you are facing the trigger boxes



Outer layer (RPC2 or Pivot Plane)

IP

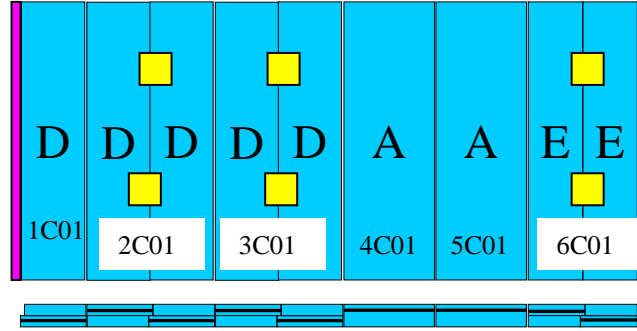
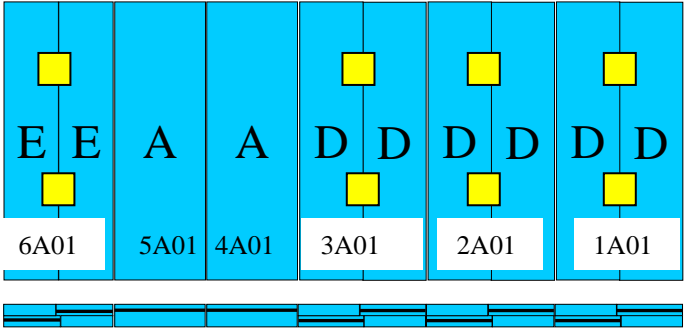
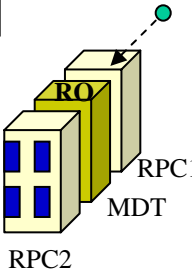

Inner layer (RPC1 or Confirm Plane)

RPC units for BML chambers - Sector 3

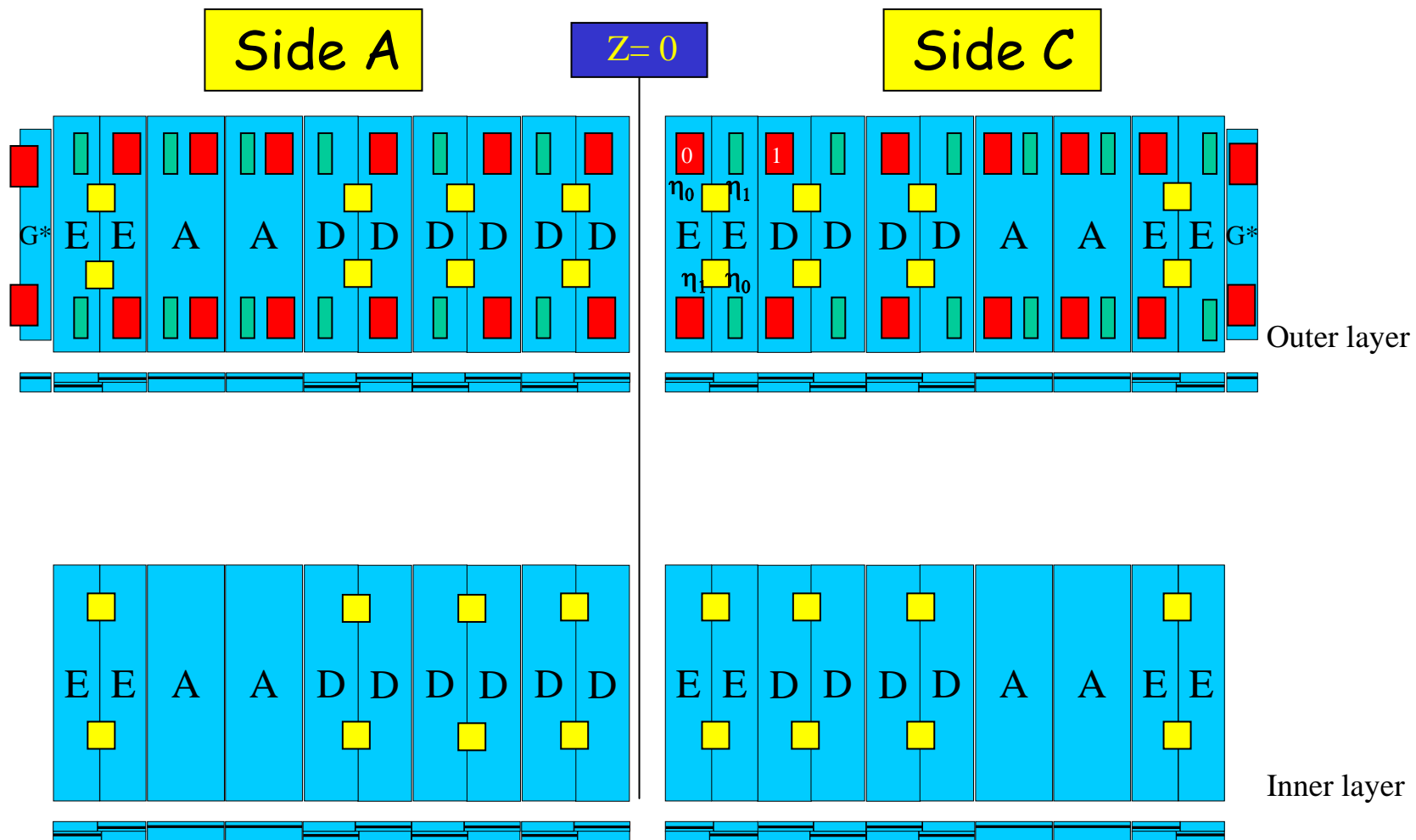

RPC units for BML chambers - Sector 5

It is like sector 3

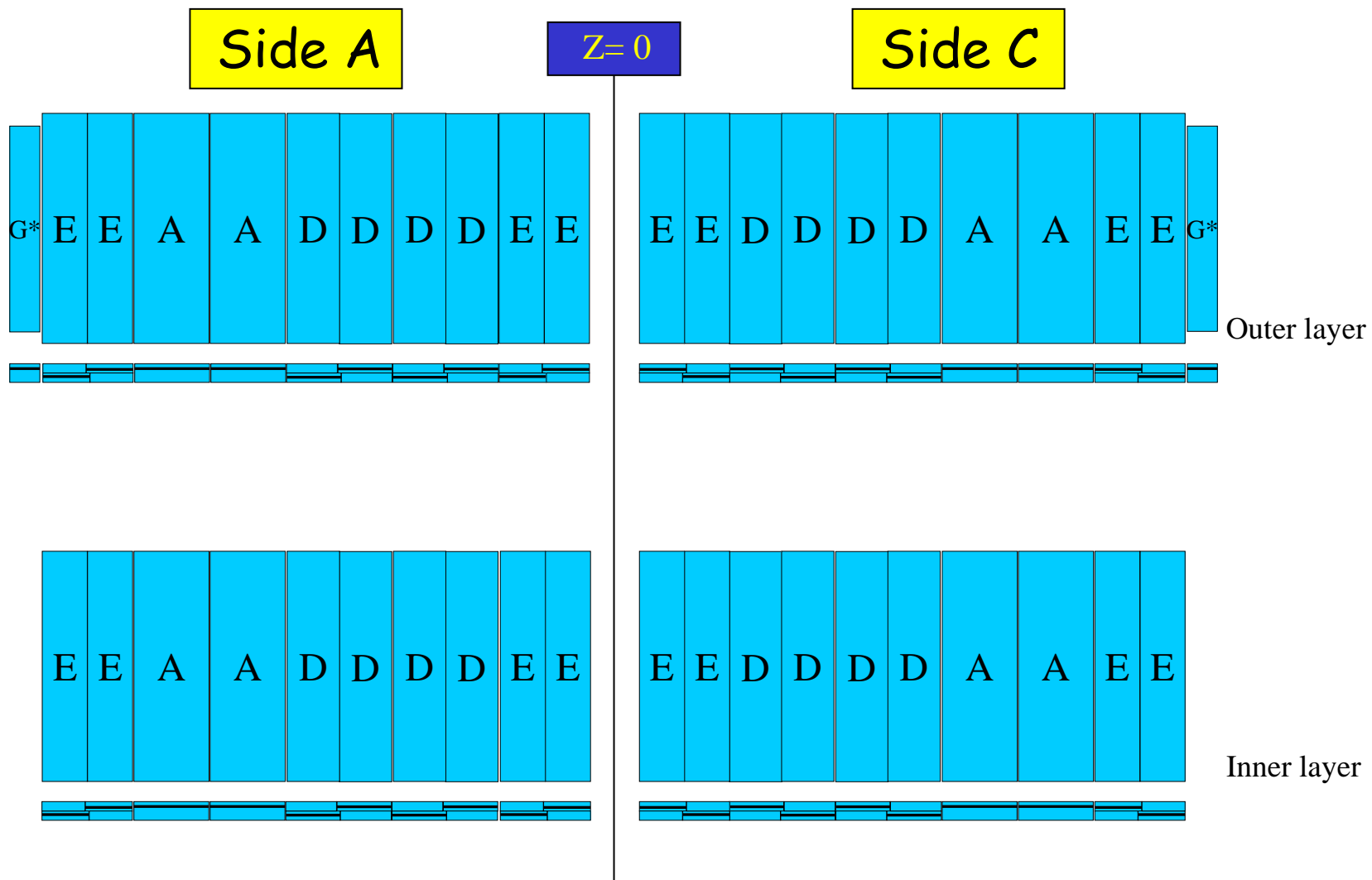

RPC units for BML chambers - Sector 7

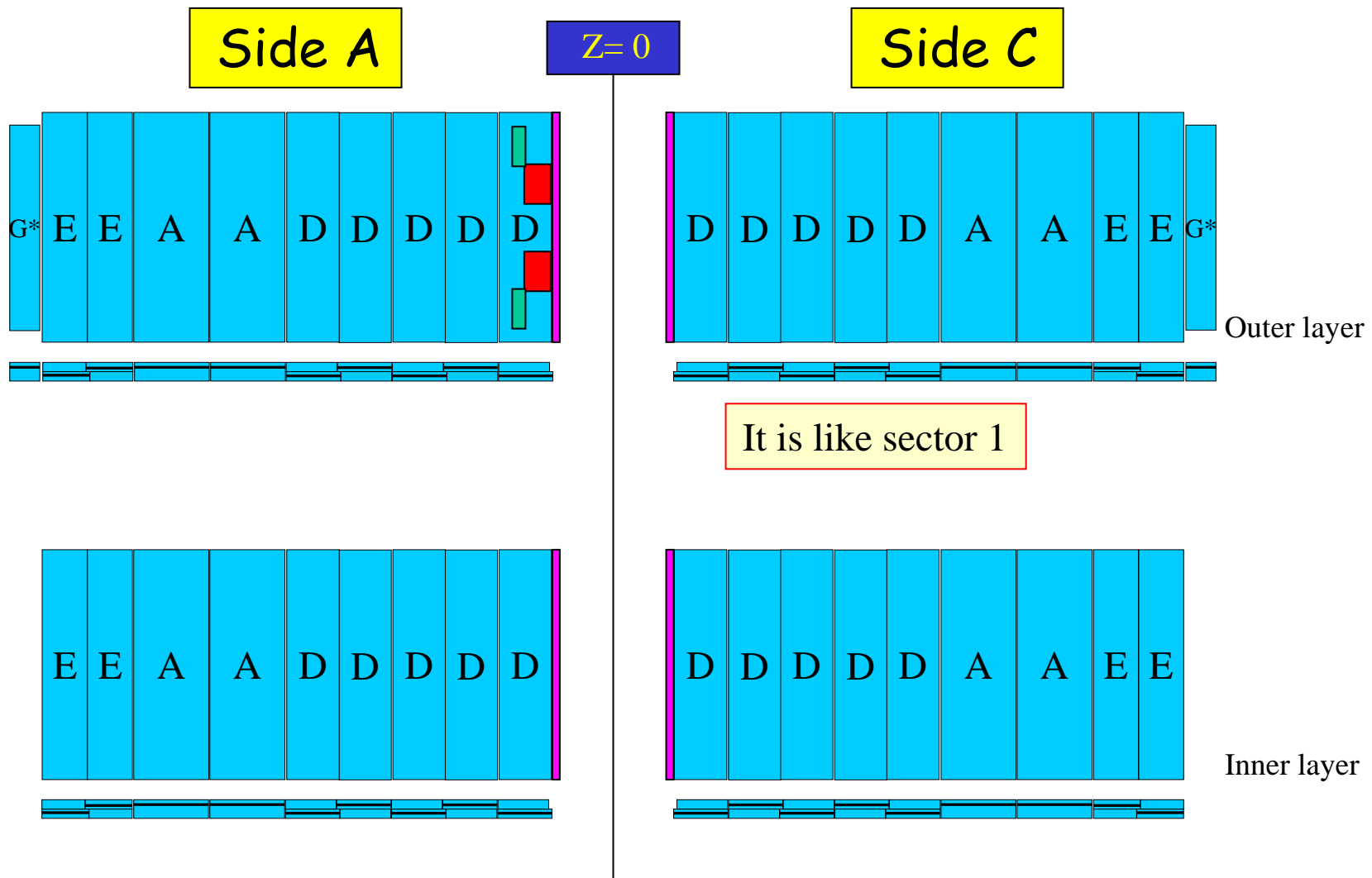

RPC units for BML chambers - Sector 9

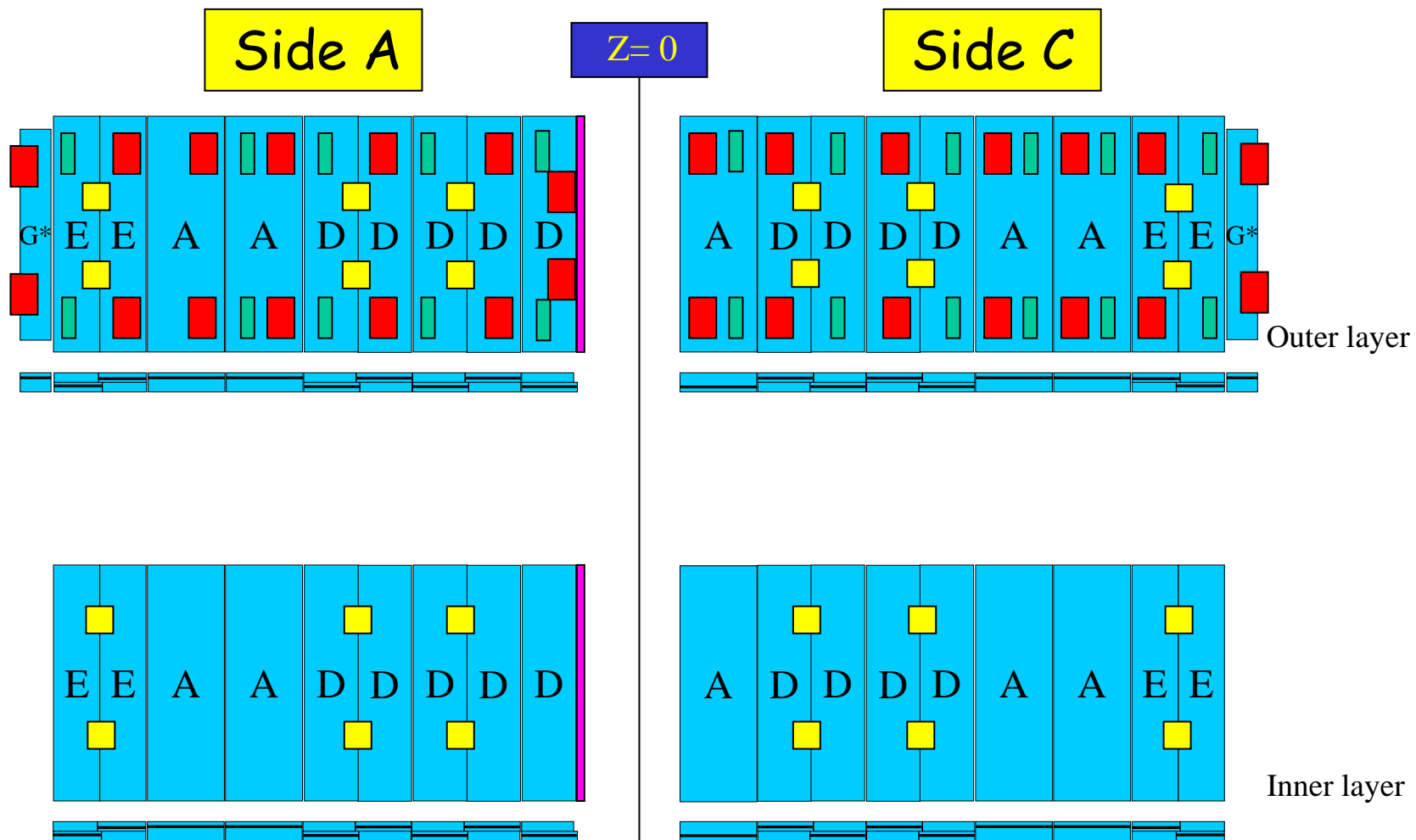

RPC units for BML chambers - Sectors 11

It is like sector 9

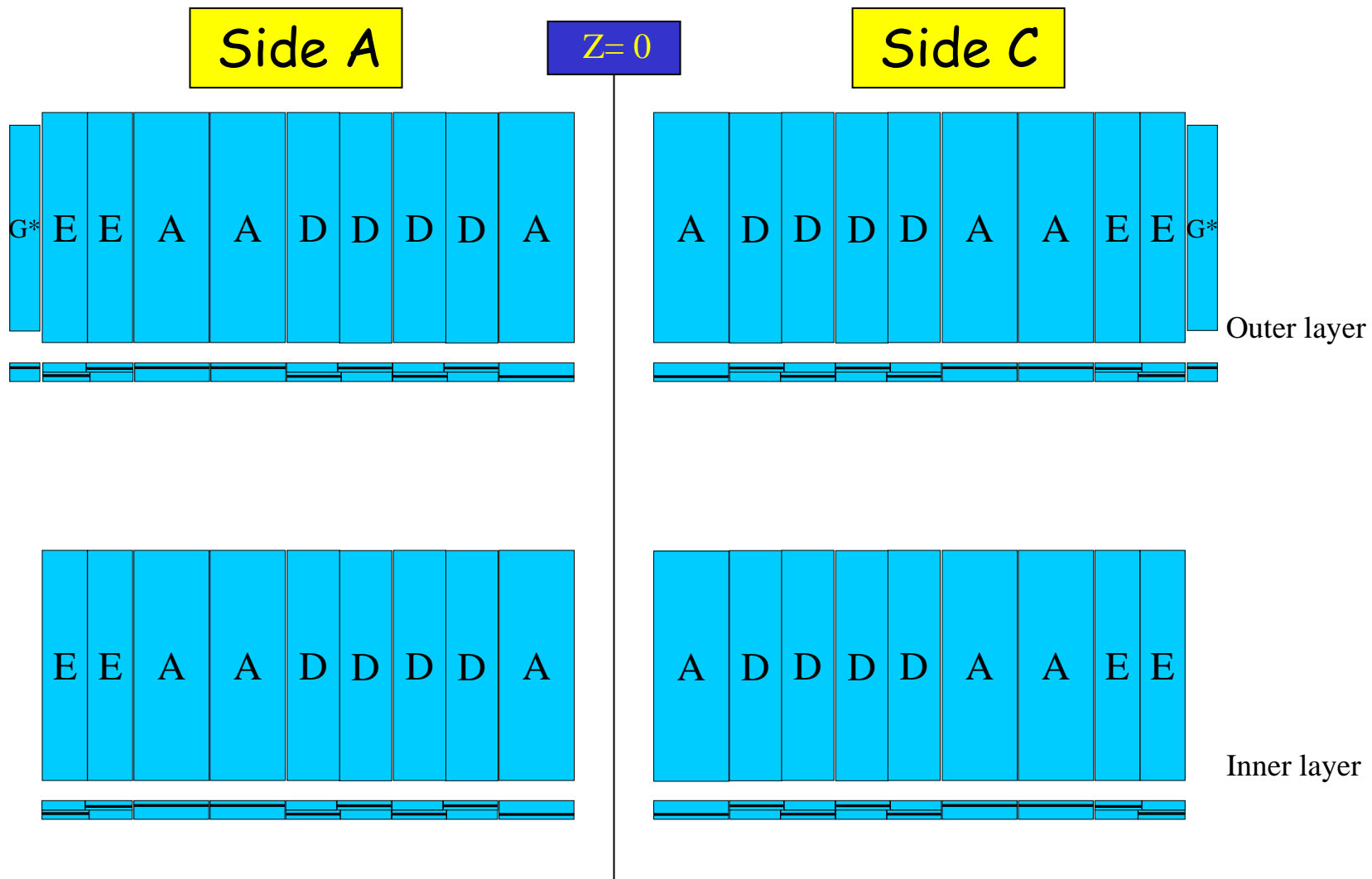

RPC units for BML chambers - Sector 13

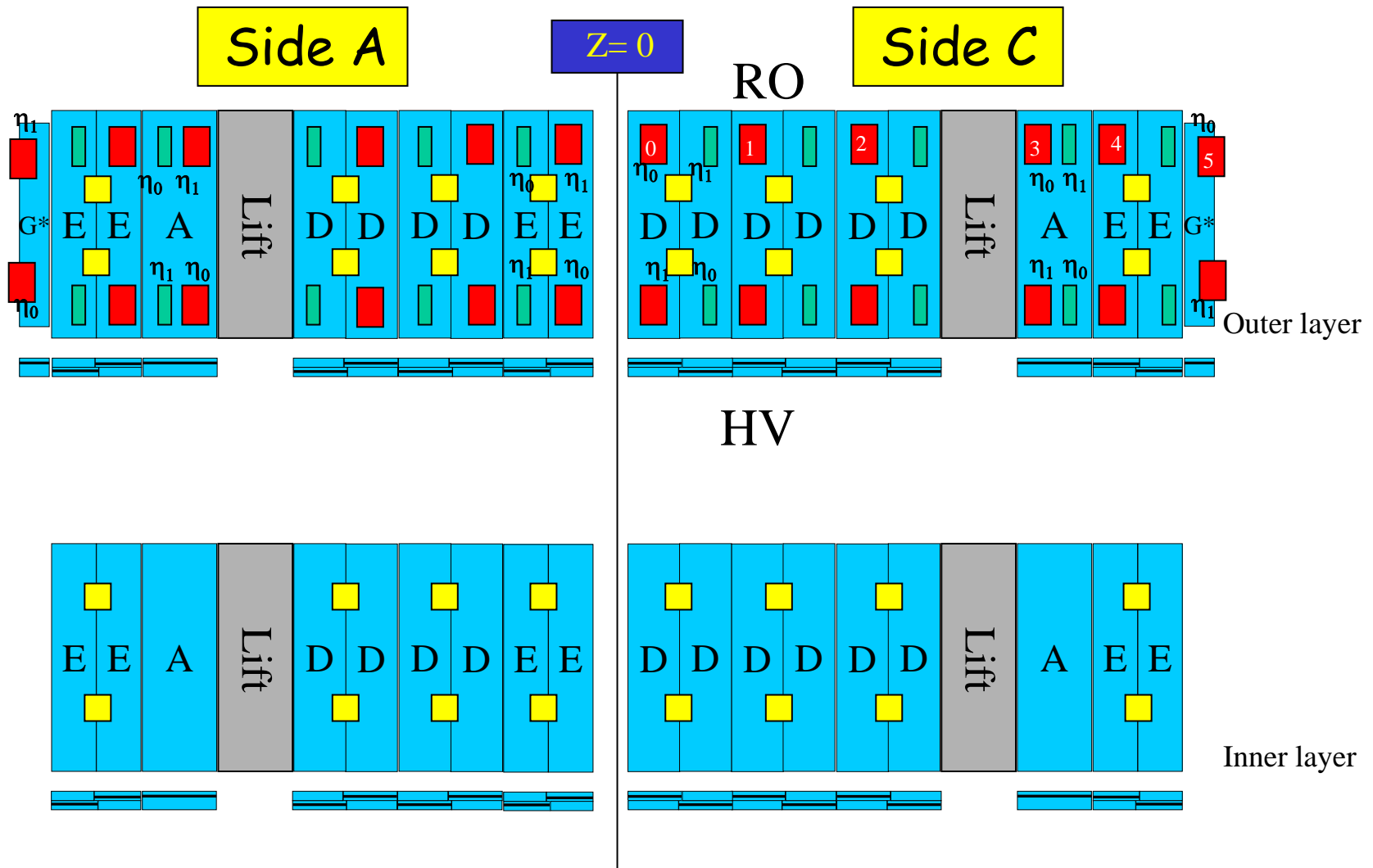

RPC units for BML chambers - Sectors 15

It is like sector 11

